

Pretest DA

MTH-4273

© CDC Vimont 2019

1. (6 marks) Use the diagram below to help answer the questions:

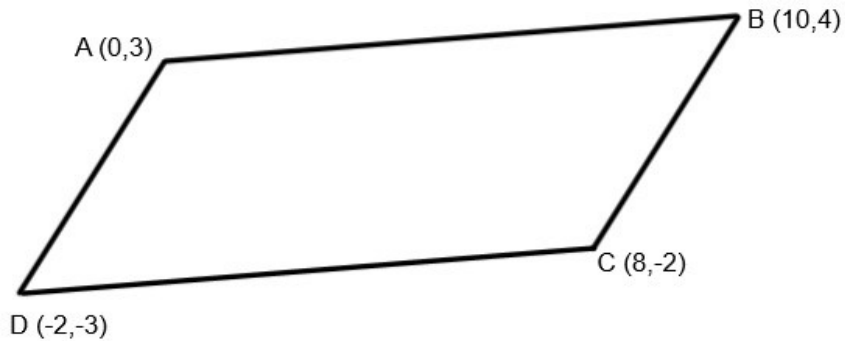

- a) Point E is found halfway between Point A and Point B. What are the coordinates of Point E?
- b) Point F is found along side AD with a ratio of 1:3. What are the coordinates of Point F?
- c) Point G is three eighths of the way along side CB. What are the coordinates of Point G?

2. (5 marks) Find the length of side AD.

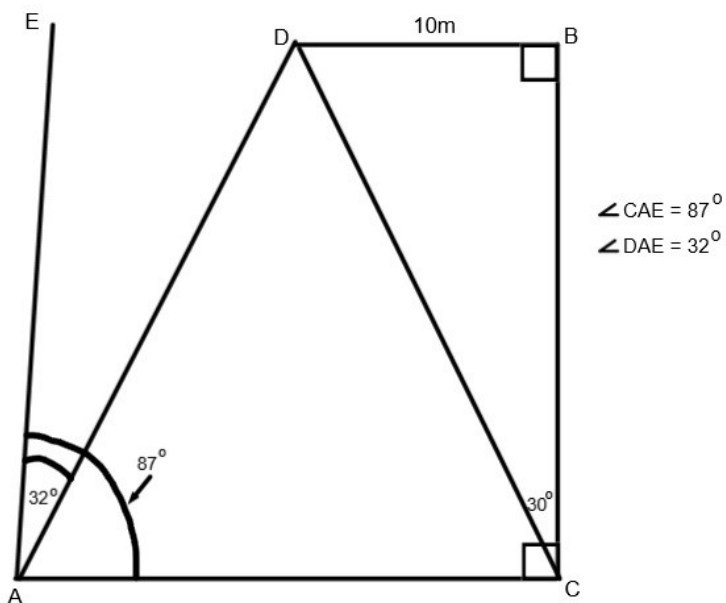

3. (6 marks)

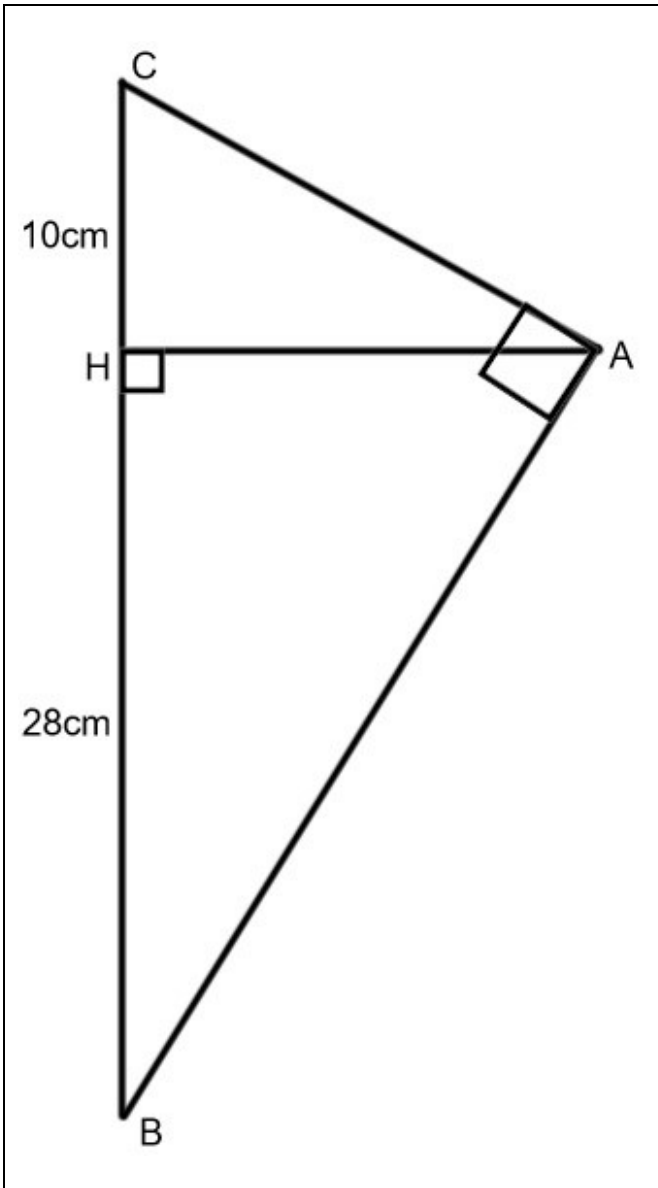
 <p>The diagram shows a right-angled triangle ABC with the right angle at vertex A. A vertical line segment BC is drawn, with point H on BC such that AH is perpendicular to BC. The length of CH is labeled as 10cm and the length of BH is labeled as 28cm. Right angle symbols are shown at H on BC and at A on BC.</p>	<p>a) How long is AH?</p> <p>b) What is the product of AB and AC? Answer without using Principle 10 or Pythagoras' Theorem.</p> <p>c) How long is AC? How long is BC? Answer without using Pythagoras' Theorem.</p>
---	--

4. (6 marks) For each of the following, say whether the two triangles are similar. In each case state the property you are applying and provide any necessary calculations to justify your answer:

<p>a)</p>	<p>b)</p>	<p>c)</p>
<p>d)</p>	<p>e)</p>	<p>f)</p>
<p>g)</p>	<p>h)</p>	<p>i)</p>
<p>j)</p> <p> $\overline{AB} = 10$ $\overline{BD} = 5$ $\overline{BC} = 10$ $\overline{BE} = 5$ </p>	<p>k)</p>	<p>l)</p>

5. (15 marks) Rounded to the nearest hundredth, what is the Area of Triangle PQR?

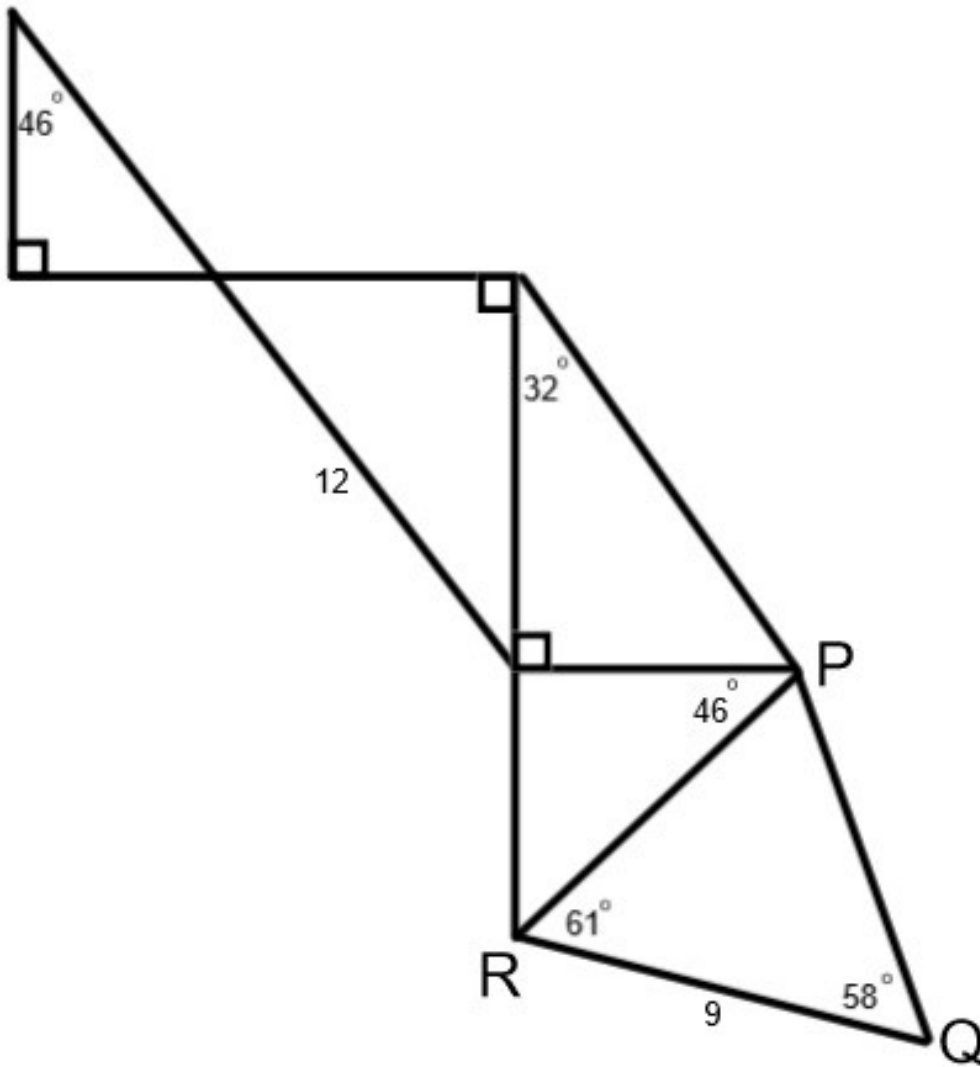

6. (6 marks) For each of the following, say whether the two triangles are congruent. In each case state the property you are applying and provide any necessary calculations to justify your answer:

<p>a)</p>	<p>b)</p>	<p>c)</p>
<p>d)</p>	<p>e)</p>	<p>f)</p>
<p>g)</p>	<p>h)</p>	<p>i)</p>
<p>j)</p>	<p>k)</p>	<p>l)</p>

7. (6 marks) Triangles ABC, DEF and GHJ are similar. How long is BC? How long is JG? How long is JK?

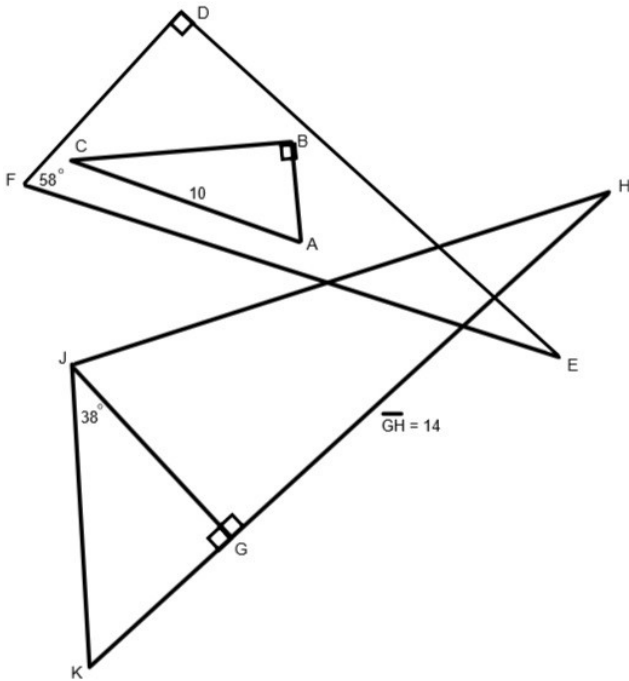

8. (20 marks) My neighbor is allowing me to use an irregularly shaped portion of their back yard as a pumpkin patch, on the agreement that I will give them some of the pumpkins when they are ripe. The section of land is represented in the following diagram, with a scale of 1 unit = 3m:

If producing 1 pumpkin requires, on average, 2m^2 of land area, how many pumpkins will we be likely to produce? Round your answer to the nearest pumpkin. **Note:** Do not use slopes or linear equations to solve this problem.

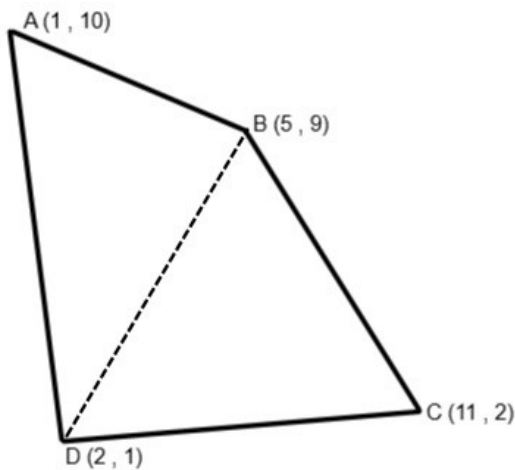

9. (5 marks) I am about to kick a ball in a straight line towards two flagpoles of equal height, positioned one directly behind the other. The flag at the top of the first pole makes an angle of 66° to the ball. The flag at the top of the second pole makes an angle of 71° to the ball. If the flags are 20m apart, how tall are the poles? Draw this situation and then answer the question.

10. (5 marks)

6 children run in straight lines, starting from Point G on a soccer field, and touch the 6 light poles that surround the field.

The speed and time for each child are given in the following table:

Child	Speed	Time
A	5.4m/s	5s
B	5m/s	7s
C	7m/s	5s
D	7.9m/s	10s
E	10m/s	7.1s
F	8m/s	3s

a) How far did each child run?
b) What is the measure of angle DGE?

11. (5 marks) Triangles JKL, LMN and JNP are congruent. What is the perimeter of triangle JLN?

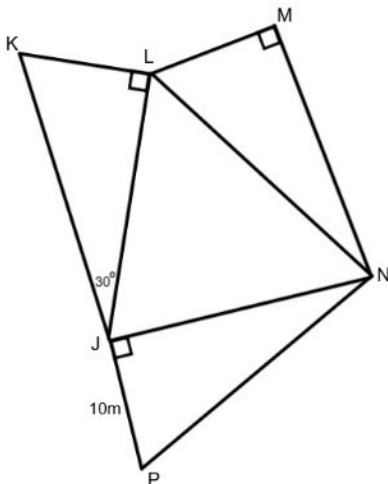

12. (5 marks) I installed a post in my back yard to hang my hammock, because we only have one tree. I strengthened the post by attaching wires from it to two spots on the ground (B and C). How long is CD?

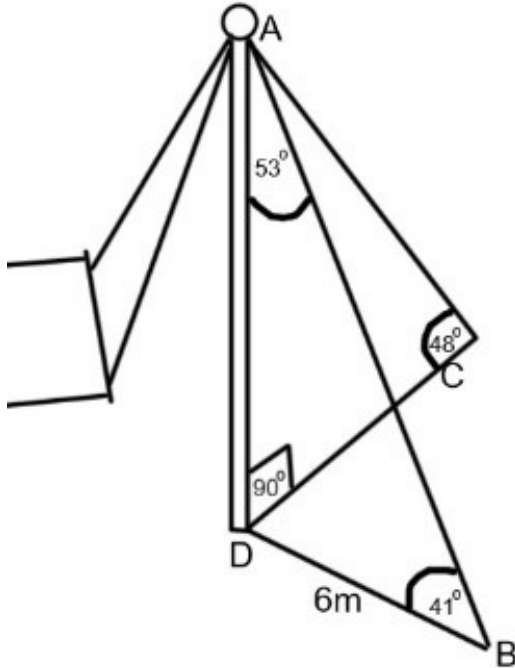

13. (5 marks)

- Draw a straight line 10cm in length. Label the endpoints P_1 and P_3 .
- About $\frac{1}{3}$ of the distance from P_1 to P_3 , draw a 3rd point. Label it P_2 .
- Label segment P_2P_3 as 100m.
- From P_1 , draw a 4cm line that is perpendicular to segment P_1P_3 . Label the other endpoint of this new line as P_4 .
- Draw a line from P_4 to P_2 . Draw a line from P_4 to P_3 .
- Label angle $P_1P_2P_4$ as 50° . Label angle $P_1P_3P_4$ as 20° .

How long is P_1P_2 ?

14. (5 marks)

- Draw a straight line 5cm in length. Label the endpoints P_1 and P_2 .
- From P_1 , draw a 12cm dotted line that is perpendicular to segment P_1P_2 .
- Draw a 10cm line connecting P_2 and the dotted line. At the point where this new line intersects the dotted line, label Point P_3 .

What is the measure of angle $P_1P_3P_2$? Justify your answer.